

Macchine Lavorazione
Sheet metal working
Blechbearbeitungsmaschi



• We reserve the right to make changes without notice.
• Die Technische Daten sind unverbindlich. Änderungen vorbehalten.

• Plate bending capacities are given for 24 kg/mm² plates strength.
• Blechbiegeleistungen sind für 24 kg/mm² blech.

MODEL
MRMS



Calandre Motorizzate Asimetriche a Tre Rulli
Questa linea di macchine meccaniche è stata disegnata e progettata per la lavorazione di spessori leggeri e medi, fino ad un massimo di 10 mm. Il campo di impiego di queste macchine è il settore della lavorazione dell'alluminio, della canalistica, della carrozzeria industriale ed in genere dei laboratori e le piccole industrie di lavorazione metallica.

Caratteristiche Tecniche ed Accessori Standard

- Corpo in acciaio elettrosaldato
- Rullo superiore apribile per estrazione virola
- Pannello mobile di comando
- Motori centrali trainanti
- Rullo folle laterale motorizzato
- Motore principale autofrenante
- Ingranaggi in bagno d'olio
- Sistema di lubrificazione centralizzato
- Dispositivo di calandatura conica ed invito
- Sistema di supporto per rullo superiore
- Rullo folle laterale montato su cuscinetti a sfera per la lavorazione di spessori sottili
- Costruita in conformità alle normative CE
- Rulli costruiti in acciaio certificato SAE 1050

Accessori Speciali

- Rulli temperati
- Rulli prolungati per la lavorazione dei profili
- Rulli per la lavorazione dei profili
- Visualizzatore digitale di quota per rullo laterale folle

Asymetrical Three-Roll Plate Bending Machines

This mechanical model is designed for light to medium jobs. It is used in jobs up to 10 mm thickness materials. It is used in Aluminium Bendings, Air Conditioning Channels, Advertising Panels and Machinery Sheet Metal Covers.

Technical Specifications and Standard Equipments

- Steel-Welded main Frames
- Openable Top Roll (Drop end)
- Mobile Control Panel
- Motor Powered centralised Rolls
- Motorised Back Roll
- Main motor with Brake system
- Gears under continuous oil bath
- Centralised Lubrication System
- Conical Bending, Pre-Bending available
- Support System for top roll
- Back Roll with Ball-Bearings for thin sheet works
- Built according to EC Safety Directives
- SAE 1050 quality Certificated Steel Rolls with high tensile strength

Special Accessories

- Hardened rolls
- Extended Roll Shafts for Section bending
- Section Bending Rolls
- Digital-Read Out for Back Roll

Asymetrische Drei-Walzen Rundbiegemaschinen

Unsere mechanische Rundbiegemaschine ist für allgemeine, leichte bis mittel schwere Arbeiten. Besonders bei der Bearbeitung von Blechstärken bis 10 mm (Aluminium, Öllüftungsbau, Werbebranche etc.)

Standardausstattung

- Stabiler Stahlschweisskonstruktion
- Mit ausschwenkbare Oberwalze
- Separates Steuerpult
- Zentralwalzen, motorisch angetrieben
- Motorische Anbiegung durch Schneckengetriebe und Motor
- Selbstbremsendes Hauptmotor
- Reduktiongetriebe im Ölbad
- Zentralschmierung
- Konischbiegeeinrichtung
- Zum mitnehmen dünne Bleche
- Hinterwalze mit Kugellager
- Anlehnung der ausschwenkbaren Oberwalze
- Gemäss CE

Sonderausstattung

- Gehärtete und geschliffene Walzen
- Verlängerte Walzen zur Aufnahme von Profilwalzen
- Digitalanzeige zur Ablesung der Hinterwalzeneinstellung

Invito Pre-Bending Anbiegung

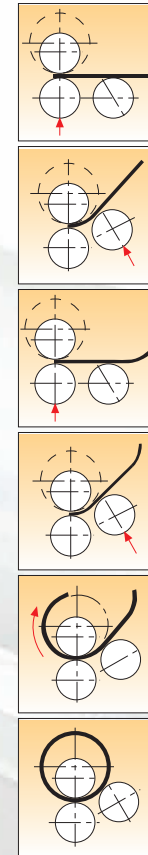

CARATTERISTICHE TECNICHE / TECHNICAL DATA / TECHNISCHE DATEN

MOD. MODEL MODELL	Lunghezza Utile Working Length Arbeitslänge	Capacità di Invito Pre-Bending Capacity Anbiegleistung	Capacità di Calandatura Bending Capacity Blechstärke	Diametro Rulli Roll Diameter Walzendurchmesser	Diametro Minimo Calandrabile Min. Bending Diameter Min. Biegedurchmesser	Potenza Motore Principale Main Motor Power Hauptmotorleistung	Potenza Motore Rullo Laterale Back Roll Motor Hinterwalzenmotor	Lunghezza Length Länge	Altezza Height Höhe	Larghezza Width Breite	Peso Weight Gewicht	
												mm.
MRMS	1050x120	1050	5	6	120	180	2.2	0.75	2550	1020	650	950
MRMS	1050x130	1050	6	7	130	195	2.2	0.75	2550	1020	650	1050
MRMS	1050x150	1050	7	8	150	225	3	0.75	2550	1040	680	1400
MRMS	1050x170	1050	8	9	170	255	4	0.75	2550	1050	720	1750
MRMS	1050x190	1050	9	10	190	285	4	1.1	2650	1300	950	1950
MRMS	1550x120	1550	4	5	120	180	2.2	0.75	3050	1020	650	1150
MRMS	1550x130	1550	5	6	130	195	2.2	0.75	3050	1020	650	1270
MRMS	1550x150	1550	6	7	150	225	3	0.75	3050	1040	680	1480
MRMS	1550x170	1550	7	8	170	255	4	0.75	3050	1050	720	1690
MRMS	1550x190	1550	8	9	190	285	4	1.1	3150	1300	950	3300
MRMS	2050x120	2050	2	3	120	180	2.2	0.75	3550	1020	650	1300
MRMS	2050x130	2050	3	4	130	195	2.2	0.75	3550	1020	650	1450
MRMS	2050x150	2050	4	5	150	225	3	0.75	3550	1040	680	1680
MRMS	2050x170	2050	5	6	170	255	4	0.75	3550	1050	720	1920
MRMS	2050x190	2050	6	7	190	285	4	1.1	3650	1300	950	3625
MRMS	2550x140	2550	2	3	140	210	3	0.75	4050	1020	650	1850
MRMS	2550x150	2550	3	4	150	225	3	0.75	4050	1020	650	1900
MRMS	2550x180	2550	4	5	180	270	4	1.1	4150	1300	950	3850
MRMS	2550x190	2550	5	6	190	285	4	1.1	4150	1300	950	3950
MRMS	3050x140	3050	1	2	140	210	3	0.75	4550	1040	680	2100
MRMS	3050x160	3050	2	3	160	240	4	0.75	4550	1050	720	2350
MRMS	3050x190	3050	3	4	190	285	4	1.1	4650	1300	950	4200
MRMS	3050x200	3050	4	5	200	300	4	1.1	4650	1300	950	4450

Pannello Mobile Di Comando Con Visualizzatore (Optional)
Optional Control Panel With Digital Read-Out
Extra Bedienpult Mit Digitalanzeigen

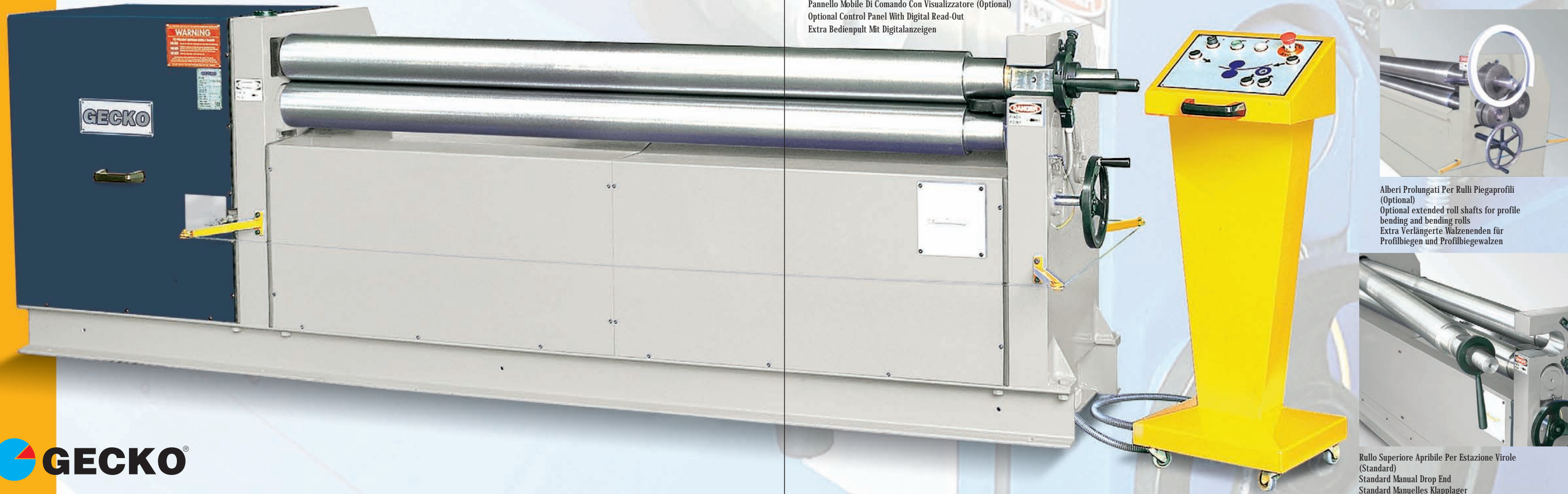

Alberi Prolungati Per Rulli Piegaprofili (Optional)
Optional extended roll shafts for profile bending and bending rolls
Extra Verlängerte Walzenenden für Profilbiegen und Profilbiegewalzen



Rullo Superiore Apribile Per Estazione Virole (Standard)
Standard Manual Drop End
Standard Manuelles Klapplager

MODEL IRM



Calandre Motorizzate Asimmetriche a Tre Rulli

Questa linea di macchine meccaniche è stata disegnata e progettata per la lavorazione di spessori leggeri e medi, fino ad un massimo di 5 mm. Il campo di impiego di queste macchine è il settore della lavorazione dell'alluminio, della canalistica, della carrozzeria industriale ed in genere dei laboratori e le piccole industrie di lavorazione metallica. Il prezzo particolarmente conveniente rende questa serie di macchine particolarmente adatte alle piccole officine metalmeccaniche.

Caratteristiche Tecniche Ed Accessori Standard

- Corpo in ghisa sferoidale
- Rullo superiore apribile per estrazione virola
- Pannello mobile di comando
- Rulli centrali trainanti
- Rullo folle laterale motorizzato
- Motore principale autofrenante
- Dispositivo di calandratura conica ed invito
- Scanalatura su rullo inferiore per calandratura lamiera bordate
- Sistema di supporto per rullo superiore
- Rullo folle laterale montato su cuscinetti a sfera per la lavorazione di spessori sottili
- Costruita in conformità alle normative CE
- Rulli costruiti in acciaio certificato SAE 1050

Accessori Speciali

- Rulli temperati
- Visualizzatore digitale di quota per rullo laterale folle
- Motorizzazione rullo posteriore

Asymetrical Three-Roll Plate Bending Machines

This mechanical model is designed for light to medium jobs. It is used in jobs up to 5 mm thickness materials. It is used in Aluminium Bendings, Air Conditioning Channels, Advertising Panels and Machinery Sheet Metal Covers. Its ideal price makes it very attractive for small workshops.

Technical Specifications and Standard Equipments

- Spheroid Cast Iron Main Frames
 - Main motor with Brake system
 - Openable Top Roll (Drop end)
 - Motor Powered centralised Rolls
 - Conical Bending, Pre-Bending available
 - Support System for top roll
 - Back Roll with Ball-Bearings for thin Sheet works
 - Mobile Control Panel
 - Wired grooves
 - Built according to EC Safety Directives
 - SAE 1050 quality certificated Steel Rolls, with high tensile strength
- ### Special Accessories
- Hardened Rolls
 - Digital-Read Out for Back Roll
 - Motorised back roll adjustment

Asymetrische Drei-Walzen Rundbiegemaschinen

Unsere mechanische Rundbiegemaschine ist für allgemeine leichte bis mittel schwere Arbeiten. Besonders bei der Bearbeitung von Blechstärken bis 5 mm (Aluminium, Öllüftungsbau, Werbebranche etc.)

Standardausstattung

- Solider Gusskörper
- Selbstbremsendes Hauptmotor
- Anlehnung der ausschwenkbaren Oberwalze
- Zentralwalzen, motorisch angetrieben
- Konischbiegeeinrichtung
- Zum mitnehmen dünne Bleche
- Hinterwalze mit Kugellager
- Drahteinlegerillen
- Walzen aus SAE 1050 Qualitätstahl
- Separates Steuerpult
- Gemäss CE

Sonderausstattung

- Gehärtete und geschliffene Walzen
- Digitalanzeige zur Ablesung der Hinterwalzeneinstellung
- Motorische Hinterwalze

CARATTERISTICHE TECNICHE / TECHNICAL DATA / TECHNISCHE DATEN

MOD. MODEL MODELL	Lungh ezza Utile Working Length	Capacità di Calandratura Bending Capacity Blechstärke	Diametro Rulli Roll Diameter Walzendurchmesser	Diametro Minimo Calandrabile Min. Biegedurchmesser	Velocità / Rotazione Rulli Roll Speed Walzengeschwindigkeit	Potenza Motore Principale Motor Power Motorleistung	Lunghezza Length Länge	Altezza Height Höhe	larghezza Width Breite	Peso Weight Gewicht
	mm.	mm.	Ø mm.	Ø mm.	rpm	Kw.	mm.	mm.	mm.	Kg.
IRM 1050x110	1050	4	110	165	8	2.2	2200	1000	750	1100
IRM 1050x130	1050	5	130	195	8	2.2	2200	1000	750	1200
IRM 1270x120	1270	4	120	180	8	2.2	2470	1000	750	1250
IRM 1270x140	1270	5	140	210	8	2.2	2470	1000	750	1320
IRM 1550x110	1550	3	110	165	8	2.2	2700	1000	750	1200
IRM 1550x140	1550	4	140	210	8	2.2	2700	1000	750	1420
IRM 2050x110	2050	2	110	165	8	2.2	3200	1000	750	1380
IRM 2050x130	2050	3	130	195	8	2.2	3200	1000	750	1450
IRM 2550x140	2550	2.5	140	210	8	2.2	3700	1000	750	1550

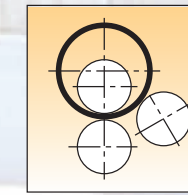
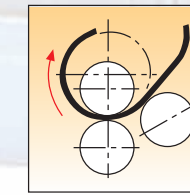
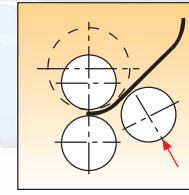
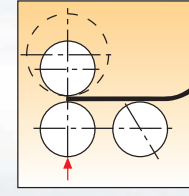
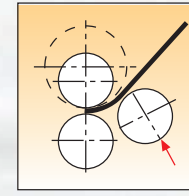
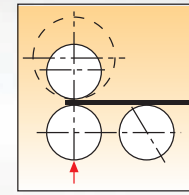

Invito / Pre-Bending / Anbiegung

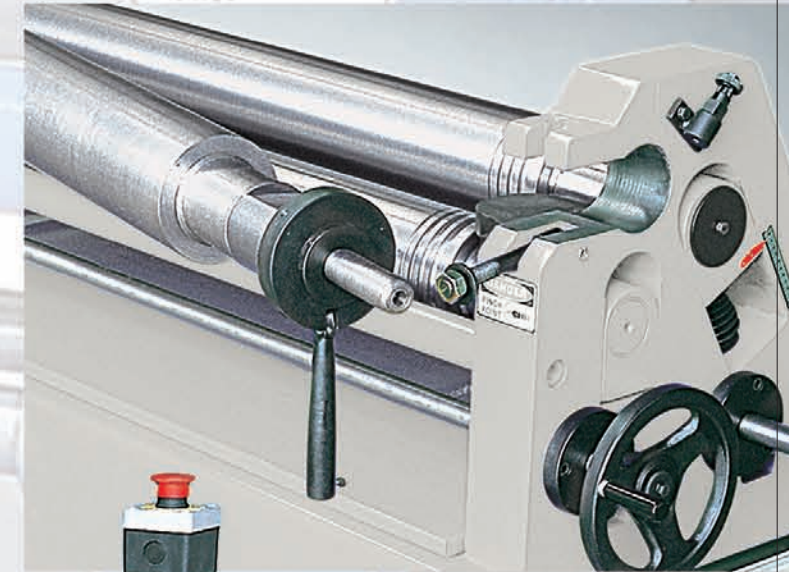

Rullo Superiore Apribile Per Estrazione Virole
(Standard)
Standard Manual Drop End
Standard Manuelles Klapplager



MODEL RM

Calandre Motorizzate e Manuali Asimmetriche a Tre Rulli

Questa linea di macchine meccaniche è stata disegnata e progettata per la lavorazione di spessori leggeri e medi, fino ad un massimo di 3 mm. Il campo di impiego di queste macchine è il settore della lavorazione dell'alluminio, della canalistica, della carrozzeria industriale ed in genere dei laboratori e le piccole industrie di lavorazione metallica. Il prezzo particolarmente conveniente rende questa serie di macchine particolarmente adatte alle piccole officine metalmeccaniche.

Caratteristiche Tecniche Ed Accessori Standard

- Corpo in ghisa
- Motore autofrenante (serie RM)
- Rullo superiore apribile per estrazione virola
- Rulli centrali trainanti (serie RM)
- Dispositivo di calandratrice conica ed invito
- Scanalatura su rullo inferiore per calandratrice lamiera bordate
- Pannello mobile di comando (serie RM)
- Costruita in conformità normative CE
- Rulli costruiti in acciaio certificato SAE 1050

Accessori Speciali

- Rulli temperati
- Motorizzazione rullo posteriore

Three-Roll Motorised and Manual Plate Bending Machines

This mechanical model is designed for light to medium jobs. It is used in jobs up to 3 mm thickness materials. It is used in Aluminium Bendings, Air Conditioning Channels, Advertising Panels and Machinery Sheet Metal Covers. Its ideal price makes it very attractive for small workshops.

Technical Specifications and Standard Equipments

- Cast Iron Main Frames
- Main motor with Brake system (PB)
- Openable Top Roll (Drop end)
- Motor Powered centralised Rolls (PB)
- Conical Bending, Pre-Bending available
- Wired Grooves
- Mobile Control Panel (PB)
- Built according to EC Safety Directives
- SAE 1050 quality certified Steel Rolls with high tensile strength

Special Accessories

- Hardened Rolls
- Motorised back roll adjustment

Asymmetrische Drei-Walzen Rundbiegemaschinen

Dieses Modell ist für leichte Arbeiten entwickelt worden. Es wird bis Blechstärke 3mm benötigt. PB Modelle sind motorisch, PS Modelle sind manuell angetrieben. Eine preisgünstige umfangreiche Maschinenplatte zur allgemeinen Bearbeitung von Leichtmetallen, bevorzugt im Öllüftungsbau in der Werbebranche im Klempnerbetrieb etc.

Standardausstattung

- Solider Gusskörper
- Selbstbremsendes Hauptmotor (PB)
- Anlehnung der ausschwenkbaren Oberwalze
- Zentralwalzen, motorisch angetrieben (PB)
- Konischbiegeeinrichtung
- Drahteinlegerillen
- Separates Steuerpult (PB)
- Gemäss CE
- Walzen aus SAE 1050 Qualitätstahl

Sonderausstattung

- Gehärtete und geschliffene Walzen
- Motorische Hintervalze



CARATTERISTICHE TECNICHE / TECHNICAL DATA / TECHNISCHE DATEN

MOD. MODEL MODELL	Lunghezza Utile Working Length Arbeitslänge	Capacità di Calandratrice Bending Capacity Blechstärke	Diametro Rulli Roll Diameter Walzendurchmesser	Diametro Minimo Calandrabile Min. Bending Min. Biegedurchmesser	Velocità Rotazione Rulli Roll Speed Walzengeschwindigkeit	Potenza Motore Principale Motor Power Motorleistung	Lunghezza Length Länge	Altezza Height Höhe	Larghezza Width Breite	Peso Weight Gewicht
RM 1050x90	1050	3	90	135	6	1.1	1630	1200	700	450
RM 1550x90	1550	2	90	135	6	1.5	2130	1200	700	600
RM 2050x95	2050	1.5	95	145	6	1.5	2630	1200	700	800
RS 1050x90	1050	3	90	135	-	-	2080	1250	700	410
RS 1550x90	1550	2	90	135	-	-	2580	1250	700	560
RS 2050x95	2050	1.5	95	145	-	-	3080	1250	700	760

■ RS Motorizzate
Motorised

■ RS Manuali
Manual

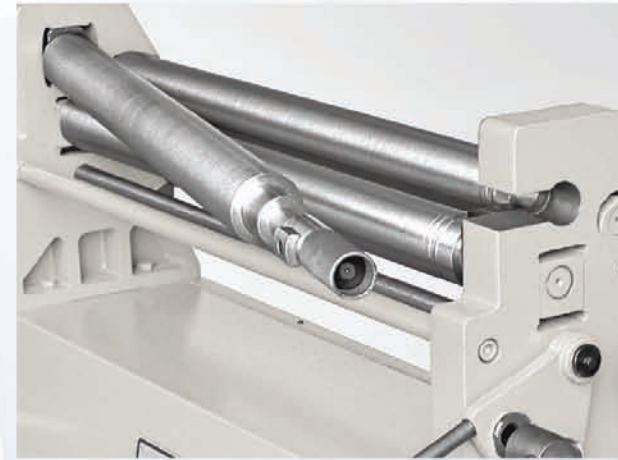

Rullo Superiore Apribile Per Estrazione Virole (Standard)
Standard Manual Drop End
Standard Manuelles Klapplager



MODEL RS



MODEL
IR

Calandre Motorizzate e
Manuali Asimmetriche
a Tre Rulli

**Caratteristiche Tecniche ed
Accessori Standard**

- Corpo in ghisa
 - Motore autofrenante (serie IR)
 - Rullo superiore apribile per estrazione virola
 - Rulli centrali trainanti (serie IR)
 - Dispositivo di calandratura conica ed invito
 - Scanalatura su rullo inferiore per calandratura lamiera bordate
 - Pannello mobile di comando (serie RM)
 - Costruita in conformità alle normative CE
 - Rulli costruiti in acciaio certificato SAE 1050
- Accessori Speciali**
- Rulli temperati

**Three-Roll Motorised and
Manual Plate Bending Machines
Technical Specifications and
Standard Equipments**

- Cast Iron Main Frames
- Main motor with Brake system (IB)
- Openable Top Roll (Drop end)
- Motor Powered centralised Rolls (IB)
- Conical Bending available
- Wired Grooves
- Mobile Control Panel (IB)
- Built according to EC Safety Directives
- SAE 1050 quality Certified Steel Rolls with high tensile strength

Special Accessories

- Hardened Rolls

**Drei-Walzen Motorische und
Manuelle Rundbiegemaschinen
Standardausstattung**

- Solider Gusskörper
- Selbstbremsendes Hauptmotor (IB)
- Anlehnung der ausschwenkbaren Oberwalze
- Zentralwalzen, motorisch angetrieben (IB)
- Konischbiegeeinrichtung
- Drahteinlegerillen
- Separates Steuerpult (IB)
- Gemäss CE
- Walzen aus SAE 1050 Qualitätstahl

Sonderausstattung

- Gehärtete und geschliffene Walzen



Rullo Superiore Apribile Per
Estrazione Virole Standard
Standard Manual Drop End
Standard Manuelles Klapplager



IR Mod. 68-75 Diametro Rulli
IR Model 68-75 Roll Diameter
IR Modelle 68-75 Walzendurchmesser

GECKO

CARATTERISTICHE TECNICHE / TECHNICAL DATA / TECHNISCHE DATEN

MOD. MODEL MODELL	Lunghezza Utile Working Length Arbeitslänge	Capacità di Calandratura Bending Capacity Blechstärke	Diametro Rulli Roll Diameter Walzendurchmesser	Diametro Minimo Calandrabile Min. Biegedurchmesser	Potenza Motore Principale Motor Power Motorleistung	Lunghezza Length Länge	Altezza Height Höhe	Larghezza Width Breite	Peso Weight Gewicht
IR 1050x46	1050	0.8	46	69	0.75	1500	1120	700	175
IR 1050x56	1050	1	56	84	0.75	1500	1120	700	195
IR 1050x68	1050	1.5	68	102	1.1	1610	1160	700	360
IR 1050x75	1050	2	75	115	1.1	1610	1160	700	385
IR 1550x68	1550	1	68	102	1.1	2110	1160	700	395
IR 1550x75	1550	1.2	75	115	1.1	2110	1160	700	420
IR 2050x75	2050	1	75	115	1.5	2610	1160	700	505
R 1050x46	1050	0.8	46	69	-	1400	1120	700	140
R 1050x56	1050	1	56	84	-	1400	1120	700	160
R 1050x68	1050	1.5	68	102	-	1930	1160	700	325
R 1050x75	1050	2	75	115	-	1930	1160	700	350
R 1550x68	1550	1	68	102	-	2430	1160	700	360
R 1550x75	1550	1.2	75	115	-	2430	1160	700	395
R 2050x75	2050	1	75	115	-	2930	1160	700	470

IR Motorizzate
Motorised

R Manuali
Manual



R Mod. 68-75 Diametro Rulli
R Model 68-75 Roll Diameter
R Modelle 68-75 Walzendurchmesser



Rullo Superiore Apribile Per
Estrazione Virole (Standard)
Standard Manual Drop End
Standard Manuelles Klapplager

R Mod. 46-56 Diametro Rulli
R Model 46-56 Roll Diameter
R Modelle 46-56 Walzendurchmesser

MODEL
R



**MODEL
IBKS 4.0**

Bordatrici Motorizzate

Caratteristiche Tecniche Ed Accessori Standard

- Corpo in acciaio elettrosaldato
- Regolazione interasse alberi
- Alberi in acciaio montati su bronzine
- Motoriduttore con sistema autofrenante
- Comando a pedale per rotazione alberi
- Basamento
- Quattro serie di rulli forniti standard
- Costruita in conformità alle normative CE

Accessori Speciali

- Movimento idraulico albero superiore
- Rulli temperati

*Power Operated
Bordering / Trimming Machines*

Technical Specifications and Standard Equipments

- Steel welded construction frame
- Adjustable idle roll
- Steel Shafts with bronze bushings
- Reduction motor with brake system
- Movement of rolls with foot pedal
- Complete with stand
- 4 Set of rolls standard
- Built according to EC Safety Directives

Special Accessories

- Movement of top roll by hydraulic system
- Special Rolls

Sickenmaschinen Mit Motor

Standardausstattung

- Stabiler Stahl-Konstruktion
- verstellbare Unterwelle
- Walzen bronzegelagert
- Selbstbremsendes Reduktormotor
- Fusspedalbedienung
- mit Untergestell
- 4 Satz Standardrollen
- gemäss CE

Sonderausstattung

- hydraulische Oberwelle
- Spezialwalzen

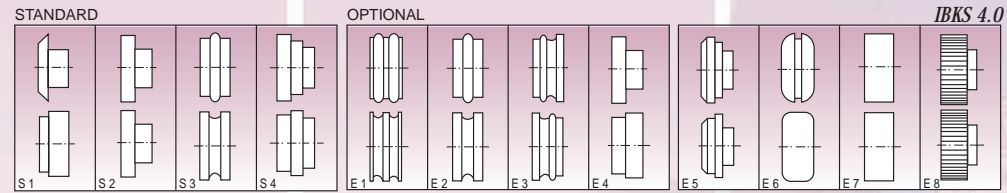

CARATTERISTICHE TECNICHE / TECHNICAL DATA / TECHNISCHE DATEN

MOD. MODEL MODELL	Lunghezza Alberi Roll Length Wellenlänge	Capacità di Bordatura Bending Capacity Blechstärke	Diametro Rulli Roll Diameter Walzendurchmesser	Incavo Throat Depth Halsweite	Numero Giri Motor Rotation Umdrehung	Potenza Motore Principale Motor Power Motorleistung	Lunghezza Length Länge	Altezza Height Höhe	Larghezza Width Breite	Peso Weight Gewicht
	mm.	mm.	Ø mm.	Ø mm.	rpm.	Kw.	mm.	mm.	mm.	Kg.
IBKS 4.0	300	4	126	200	12	2.2	1700	1200	570	500
IBKS 2.5	250	2.5	106	160	16	1.5	1400	1120	550	380

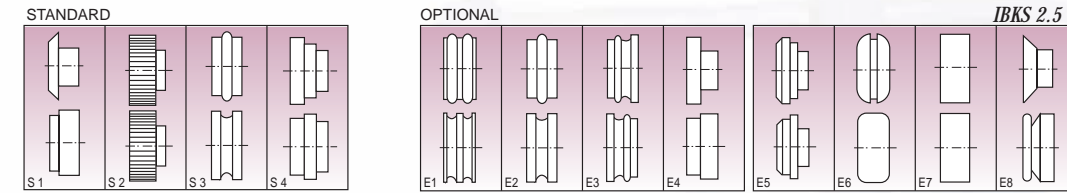

Applicazioni / Applications / Beispiele

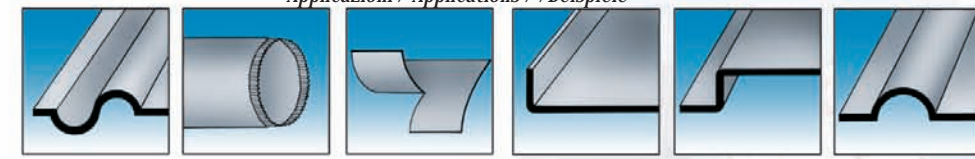

*Movimento idraulico Rullo Sup.
(Optional)
Optional hydraulic top roll
Hydraulische Oberwelle*

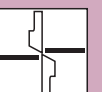
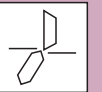
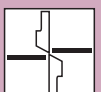

MODEL
IKMP 1.2

Bordatrici Motorizzate e Manuali

Caratteristiche Tecniche Ed Accessori Standard

- Corpo in ghisa
- Regolazione interasse alberi
- Supporto posteriore regolabile
- Motoriduttore con sistema autofrenante
- Comando a pedale per rotazione alberi
- Basamento
- Quattro serie di rulli forniti standard
- Costruita in conformità alle normative CE

Accessori Speciali

- Movimento idraulico albero superiore
- Rulli temperati

Power Operated Trimming/Bordering Machine

Technical Specifications and Standard Equipments

- Cast iron heavy duty main frame
- Adjustable side support
- Reduction motor with brake system
- Easy to carry for workshops
- Movement by foot pedal
- Adjustable idle roll
- 8 set of rolls standard
- Complete with stand
- Built according to EC Safety Directives

Applicazioni / Applications / Beispiele

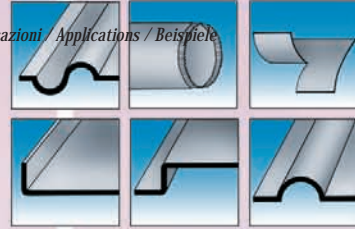

Sickenmaschine Mit Motor

Standardausstattung

- Stabiler Gusskörper
- Selbstbremsendes Reduktormotor
- Leicht zu Tragen
- Fusspedalbedienung
- verstellbare Unterwelle
- Spezialstahlwellen
- 8 Satz Standardrollen
- mit Untergestell
- gemäss CE



STANDARD *IKMP 1.2*

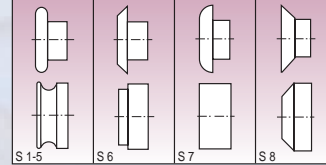

OPTIONAL

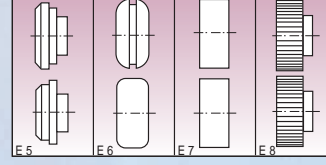
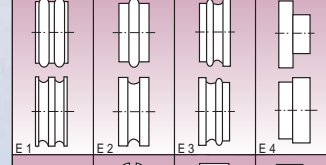

CARATTERISTICHE TECNICHE / TECHNICAL DATA / TECHNISCHE DATEN

MOD. MODEL MODELL	Lunghezza Alberi Roll Length Wellenlänge	Capacità di Bordatura Bending Capacity Blechstärke	Diametro Rulli Roll Diameter Walzendurchmesser	Incavo Throat Depth Halsweite	Numero Giri Motor Rotation Umdrehung	Potenza Motore Principale Motor Power Motorleistung	Lunghezza Length Länge	Altezza Height Höhe	Larghezza Width Breite	Peso Weight Gewicht
	mm.	mm.	Ø mm.	Ø mm.	rpm	Kw.	mm.	mm.	mm.	Kg.
IKMP 1.2	140	1.2	62	100	32	0.75	900	1350	450	110
IK 1.2	140	1.2	62	100	-	-	560	500	220	50
IK 0.8	110	0.8	52	80	-	-	380	380	180	30

STANDARD *IK 1.2*

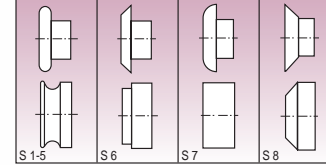

OPTIONAL

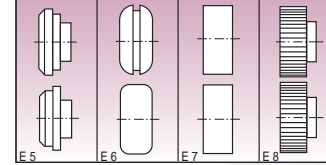
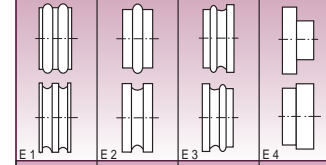

4 Serie rulli standard
4 Sets of standard rolls
4 Satz Standardrollen

4 Serie rulli standard
4 Sets of standard rolls
4 Satz Standardrollen

STANDARD *IK 0.8*

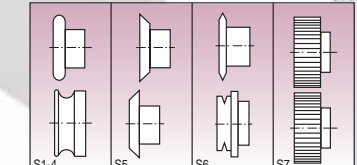

OPTIONAL

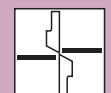
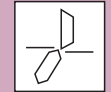
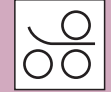
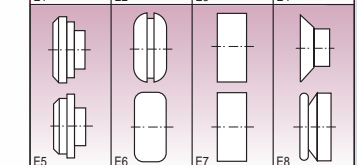
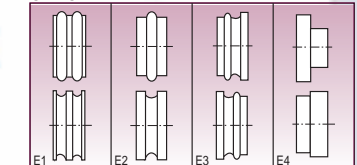

MODEL
IK12-08

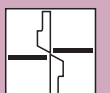
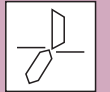

MODEL
IDK 5

MODEL
IDK 2-1

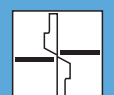
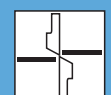
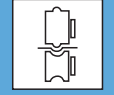
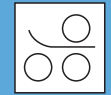

Cesoie Circolari Tagliadischi Motorizzate

Motorised Circular Cutting Shear

Kreisschere Mit Motor

Caratteristiche Tecniche Ed Accessori Standard

Technical Specifications and Standard Equipments

Standardausstattung

- Corpo in acciaio elettrosaldato
- Chiusura oledinamica
- Lame inclinate in acciaio speciale
- Alberi montati su bronzine
- Motoriduttore con sistema autofrenante
- Archetto portapezzo motorizzato
- Pannello mobile di comando
- Sistema di lubrificazione centralizzato
- Possibilità di taglio di diametri interni
- Costruita in conformità alle normative CE

- Steel welded construction frame
- Pneumatic clamp on center
- Special steel blades with angle
- Blades with bronze bushings
- Reduction motor with brake
- Motorised sheet centering system
- Mobile control panel
- Centralised Lubrication system
- Inside diameter cutting
- Built according to EC Safety Directives

- stabiler Stahl-Konstruktion
- pneumatisches Blechhaltesystem serienmässig
- Messer aus Spezialstahl
- Selbstbremsendes Reduktormotor
- motorisches Zentriersystem
- fahrbares Steuerpult
- Zentralschmierung
- Innenschnittsystem
- gemäss CE

Cesoie Circolari Tagliadischi Motorizzate e Manuali

Motorised and Manual Circular Cutting Shears

Motorische und manuelle Kreisscheren

Caratteristiche Tecniche Ed Accessori Standard

Technical Specifications and Standard Equipments

Standardausstattung

- Corpo in ghisa
- Lame inclinate in acciaio speciale
- Alberi montati bronzine
- Motoriduttore con sistema autofrenante (serie IDK 2)
- Pannello mobile di comando (serie IDK 2)
- Sistema di lubrificazione centralizzato (serie IDK 2)
- Possibilità di taglio di diametri interni
- Costruita in conformità alle normative CE

- Rigid Cast Frame
- Special steel blades with angle
- Blades with bronze bushing
- Reduction motor with brake (ICC 2)
- Mobile control panel (ICC 2)
- Centralised Lubrication System (ICC 2)
- Inside diameter cutting
- Built according to EC Safety Directives

- stabiler Gusskörper
- Messer aus Spezialstahl
- Messer, bronzegelagert
- Selbstbremsendes Reduktormotor (ICC 2)
- fahrbares Steuerpult (ICC 2)
- Zentralschmierung (ICC 2)
- Innenschnittsystem
- gemäss CE
- Sonderausstattung
- pneumatisches Blechhaltesystem

Accessori Speciali

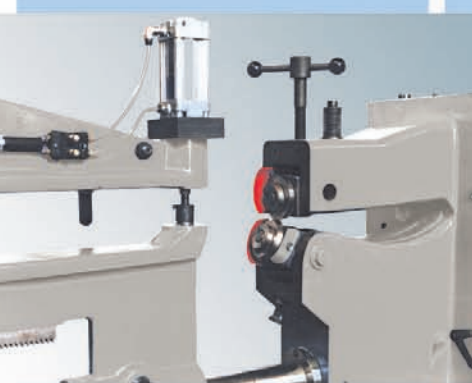

IDK 2 Chiusura Pneumatica (optional) Optional Pneumatic Clutch Pneumatisches Blechhaltesystem

IDK 1 Cesoia Tagliadischi Manuale Manual Circular Cutting Shear Manuelle Kreisschere



IDK 2 Cesoia Tagliadischi Mot. Motorised Circular Cutting Shear Kreisschere Mit Motor

IDK-5 H Chiusura Idraulica (Optional) Optional Hydraulic Clutch Hydraulische Klemmung

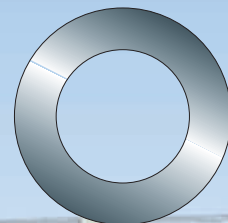

Taglio Diametri Interni (Standard) Standard Inside Diameter Cutting Standard Innenschnittsystem

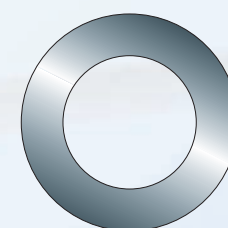

Aglio Diametro Interni (Standard) Standard Inside Diameter Cutting Standard Innenschnittsystem

CARATTERISTICHE TECNICHE / TECHNICAL DATA / TECHNISCHE DATEN

MOD. MODEL MODEL	Diametro Lavorabile Sheet Diameter Rondendurchmesser	Spessore Lavorabile (res.42 kg/mm ²) Sheet Thickness Schnittkapazität	Velocità Speed Geschwindigkeit	Acciaio Lame Blade Material Werkstoff	Potenza Motore Principale Motor Power Motorleistung	Incavo Archetto Hump Depth Ausladung	Incavo Testa Portalamo Throat Depth Halsweite	Lunghezza Length Länge	Altezza Height Höhe	Larghezza Width Breite	Peso Weight Gewicht
	Ømm.	mm.	m/min.	K	kW	mm.	mm.	mm.	mm.	mm.	Kg.
IDK 5	1400	5	4.1	2842	2.2	880	300	2500	1400	750	1060
IDK 2	1000	2	7.5	2842	1.1	700	280	1400	1150	400	300
IDK 1	1000	1	-	2842	-	600	200	1200	350	200	45



MODEL
CKS/CKL

Piegatrici Manuali a Tavola
Con Utensili a Settori

Caratteristiche Tecniche Ed
Accessori Standard

- I modelli CKS e CKL sono costituiti da un corpo in acciaio elettrosaldato e si orientano verso un utilizzo nei settori della produzione di scatolati e pannelli grazie alla modularità dei loro utensili a settori.
- Entrambi i modelli sono indicati per la lavorazione di materiali di piccole e medie dimensioni richiedendo l'impiego di un solo operatore. La tavola mobile di piegatura viene agevolata nel movimento da un sistema di molle che riduce lo sforzo dell'operatore.
- Il modello CKS consente una facile pinzatura del materiale da piegare attraverso un sistema mobile del cappello superiore. Non è necessaria nessuna regolazione in base allo spessore.
- Nei modelli CKL il cappello superiore può essere bloccato tramite un pedale tramite un pedale in modo che l'operatore possa utilizzare entrambe le mani.

Standard Specifications

Technical Specifications and
Standard Equipments

- The CKS/CKL range of sheet folders feature all welded steel frame models which are available either in straight execution with one-piece blade or in box & pan type execution with segmented blades. Both models are very convenient for medium-size batch production due to simplicity of operation by one operator. The folding beam movement is supported by a spring system which reduces the manual force required for bending.
- The CKS models allow easy clamping of material by means of a clamping lever on the top beam. On these models no thickness adjustment is necessary.
- On the CKL models the top beam can be locked by foot so that the operator can use both hands for a controlled fold.

Standardausrüstung

Standardausstattung

- Die CKS/CKL-Serie Blechslanzen zeichnet sich durch einen komplett geschweißten Stahlrahmen aus. Es ist ein Modell mit gerader Ausführung mit einem einteiligen Messer oder ein Modell in einer Ausführung mit Fingertyp mit segmentierten Bessem lieferbar. Beide Modelle sind für die Produktion mittelgrosser Partien sehr geeignet, dank der Tatsache, dass die Maschine auf einfache Weise von einem einzigen Person bedient werden kann. Die Bewegung des Stanzbalkens wird durch die zum Federmechanismus unterstützt, wodurch die zum Biegen erforderliche Handkraft wesentlich verringert wird.
- Bei den CKS-Modellen kann das Material auf einfache Weise durch einen Klemmhebel auf dem Oberbalken arretiert werden. Bei diesen Modellen braucht die Diche nicht eingestellt werden.
- Bei den CKL-Modellen kann der Oberbalken mit dem Fuss verriegelt werden, so dass die Person, die die Maschine bedient, beide Hände für eine kontrollierte Stanzbearbeitung benutzen kann.

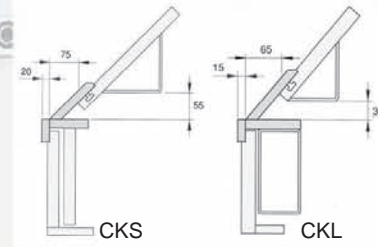

CARATTERISTICHE TECNICHE / TECHNICAL DATA / TECHNISCHE DATEN

MOD. MODEL MODELL	Lunghezza Utile Working Length Arbeitslänge	Spessore Lavorabile (res. 37 kg/mm ²) Folding Capacity (37 kg/mm ²) Biegeleistung 37 kg/mm ²	Corsa Tavola Superiore Regolabile Top Beam Stroke Oberwangenhub	Angolo Di Piegatura (max) Folding Angle (max) Biegewinkel	Lunghezza Length Länge	Altezza Width Breite	Larghezza Height Höhe	Peso Weight Gewicht
	mm.	mm.	mm.	grad/deg	mm	mm.	mm.	Kg.
CKS 2060x1.5	2060	1.5	120	135°	2750	550	1270	1050
CKL 1260x1.5	1260	1.5	40	135°	1570	860	1170	330



MODEL
CK

Piegatrici Manuali a Tavola

Caratteristiche Tecniche Ed
Accessori Standard

- Sistema di sollevamento tavola di piegatura a sforzo ridotto
- Tavola frontale a regolazione assiale
- Corpo in ghisa
- Possibilità di esecuzione pieghe con angolo molto ridotto
- Sistema di bilanciamento a contrappesi
- Costruita in conformità alle normative CE

Manual Folding Machines

Technical Specifications and
Standard Equipments

- Load lever system of the machine reduces the sheet metal bending force
- Mobile front beam offers the possibility of axial adjustment
- Cast iron body
- Knives made of production steel, in appropriate sizes, were attached to all beams
- Balancing load is available at standard models

Schwenkbiegemaschinen

Standardausstattung

- leichtes Handling durch aufwendiges Gegengewichtsystem
- Schwere Gussausführung
- Gradeinstellung für Biegewinkel mit Anschlag
- leichte Verstellung der Oberwange über Spindel
- Verstellmöglichkeit der Unterwange



CK 15/2.0



CK 20/2.0

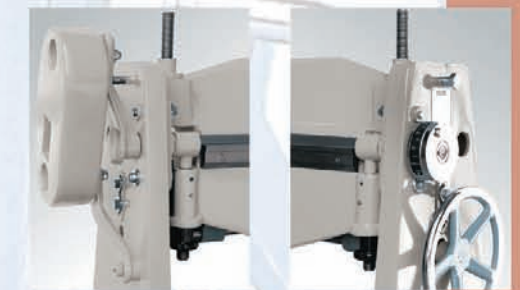

CARATTERISTICHE TECNICHE / TECHNICAL DATA / TECHNISCHE DATEN

MOD. MODEL MODELL	Lunghezza Utile Working Length Blechbreite	Spessore Lavorabile (res. 42 kg/mm ²) Folding Capacity ST-45 Biegeleistung ST 45	Corsa Tavola Superiore Regolabile Top Beam Stroke Oberwangenhub	Corsa Tavola Inferiore Regolabile Folding Beam Stroke Unterwangenhub	Angolo Di Piegatura (max) Folding Angle (max) Biegewinkel	Lunghezza Length Länge	Altezza Width Breite	Larghezza Height Höhe	Peso Weight Gewicht
	mm.	mm.	mm.	mm.	grad/deg	mm	mm.	mm.	Kg.
CK 12/2.5	1260	2.5	160	70	135°	2000	650	1250	840
CK 20/2.0	2050	2	210	100	135°	3300	750	1350	2000

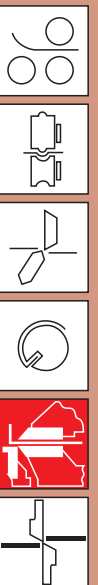

**MODEL
KM 12**

*Caratteristiche Tecniche Ed
Accessori Standard*

- Corpo e basamento in ghisa
- Largo ed ampio tavolo di appoggio facilitano le operazioni dell'operatore
- Lame costruite in acciaio al carbonio per garantire flessibilità e stabilità
- Sistema premilamiera meccanico per impedire il movimento della lamiera durante il taglio
- Contrappeso per il sollevamento del porta coltello
- Squadra frontale per tagli inclinati e registro a regolazione millimetrica per lunghezza taglio
- Costruita in conformità alle normative CE

Manual Arm Guillotine Shear

*Technical Specifications and
Standard Equipments*

- Cast iron table and foot bases. Large table facilitating the command of sheet metal by operator.
- Cutting lever made of low carbon steel for the purposes of flexibility and stability
- Mechanical pressure system which prevents sliding of sheet metal during cutting operation. Mono-block lower knife made of air hardening steel (Spk-2080) Front set-square appropriate for angle sheet metal cutting and millimeter set-square appropriate for vertical cutting.

Tafelschere

Standardausstattung

- Schwerer Gusskörper. Breites Tisch durchschiebbar für grössere Längen. Robuster, verstellbarer Griff. Schnellklemmender Niederhalter.
- Viereitig verwendbares ober-und Untermesser. Schnellverstellbarer Breitenanschlag.



CARATTERISTICHE TECNICHE / TECHNICAL DATA / TECHNISCHE DATEN

MOD MODEL MODELL	Dimensioni Tavola Table Dimension Tischgrösse	Lunghezza Taglio Blade Length Messertlänge	Lunghezza Lama Shearing Length Schnittlänge	Capacità di Taglio (Res. 42 kg/mm²) Shearing Capacity Blechstärke	Corsa Riscontro Back Gauge Length Verstellung des Breitenanschlag	Lunghezza Length Länge	Altezza Width Breite	Larghezza Height Höhe	Peso Weight Gewicht
	mm.	mm.	mm.		mm.	mm.	mm.	mm.	kg.
KM 12	600x1300	1050	1000	1.5	600	1930	1000	1330	500

**MODEL
RP, LS
BR, N**

STANDARD AUSRÜSTUNG

- Stabiler stahlkörper
- Messer aus spezialstahl

STANDARD SPECIFICATIONS

- Stable steel welded frame-construction
- Special steel blades

MODEL	—	—	—
Schwarz Blech Sheet 10 5 RP LS-16 LS-16	mm	10	-
Flacheisen Flat bar	mm	90x14	-
Ø Eisen Ø Round	mm	22	-
∕ Eisen ∕ Square	mm	20	-
L Blechwinkel L Angle	mm	60x7	-
T Blechwinkel T Angle	mm	60x7	-
Ø 13	mm	□ 10	□ 10
Ø 22	mm	□ 5.8	□ 5.8
Ø 45	mm	□ 2.8	□ 2.8
Gewicht Weight	kg	158	68
Abmessungen (BxLxH) Dimensions (WxLxH)	mm	270x900x990	220x450x740

MODEL	—	—	—
Schwarz Blech Sheet 5 RP	mm	10	8
Flacheisen Flat bar	mm	90x14	100x9
Ø Eisen Ø Round	mm	22	16
∕ Eisen ∕ Square	mm	20	-
L Blechwinkel L Angle	mm	60x7	40x6
T Blechwinkel T Angle	mm	60x7	40x6
Gewicht Weight	kg	107	55
Abmessungen (BxLxH) Dimensions (WxLxH)	mm	270x750x700	250x500x520

MODEL	mm	—	—	—	—
Schwarz Blech Sheet 3BR	mm	5 2BR	6 2BR	5	4
Flacheisen Flat bar	mm	70X5	50X6	50X5	50X4
Ø Eisen Ø Round	mm	13	13	11	10
Gewicht Weight	kg	30	17	10	9
Abmessungen (BxLxH) Dimensions (WxLxH)	mm	160x520x440	130x360x380	130x320x360	130x320x360

MODEL	mm	—	—	—	—
Flacheisen Flat bar	mm	25x8	45x10	45x12	45x14
∕ Eisen ∕ Square	mm	18	22	25	28
Ø Eisen Ø Round	mm	22	26	28	32
Gewicht Weight	kg	28	38	54	74
Abmessungen (BxLxH) Dimensions (WxLxH)	mm	190x330x350	200x440x400	220x550x420	210x640x410

